

# COMBINÉ SPORTIF 1

REF : PS-50

Conforme aux normes  
FD S 52-903  
NF EN 16630



4

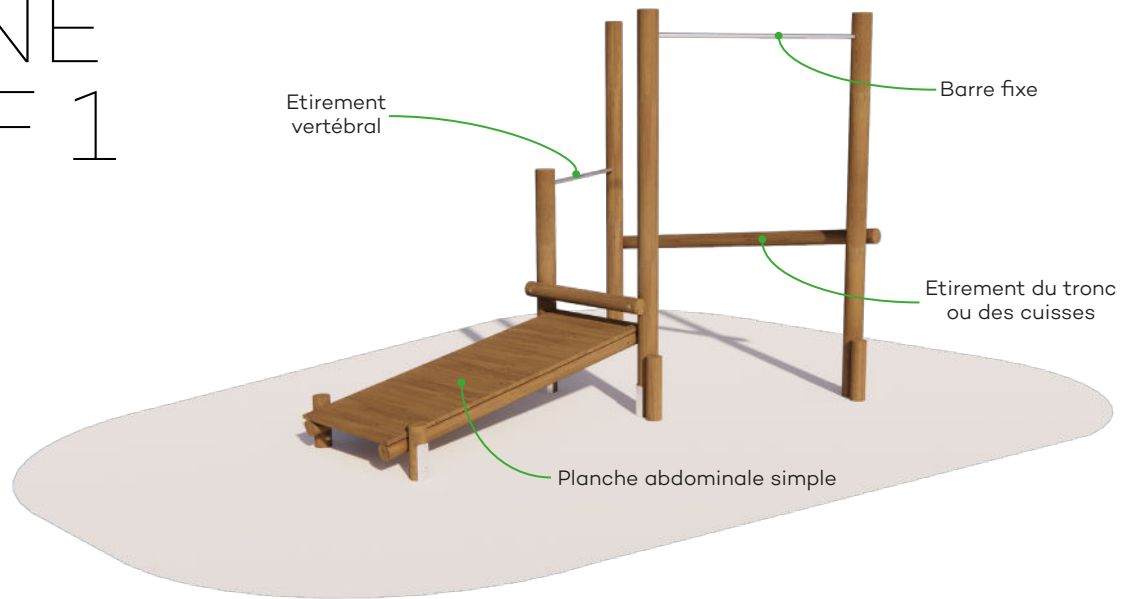

Lorem ipsum

## DIMENSIONS

Longueur : 3430 mm  
Largeur : 2345 mm  
Hauteur : 2500 mm  
Surface utile : 6430 x 5345 mm  
Espace d'évolution : 28 m<sup>2</sup>  
H.C.L. : 1321 mm  
Poids : 205 kg

## MATÉRIAUX

Pin classe 4  
Barres inox  
Visserie et boulonnerie inox  
Pieds de scellement galvanisés  
à chaud

## INSTALLATION

A sceller

## SIGNALISATION

Plaque QR code associée à chaque  
atelier (voir détails au verso)

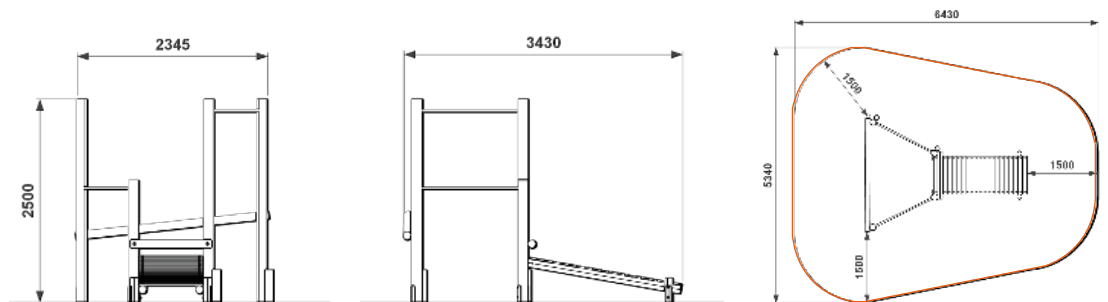

**Rondino®**

rue de l'industrie  
Z.I. du Champ de Mars  
42600 SAVIGNEUX

☎ 04 77 96 29 81

✉ info@rondino.fr

www.rondino.fr



# SIGNALISATION

Plaque aluminium intégrée dans coque rigide vissée sur poteau bois  
 Ø100mm lg. 2000 mm

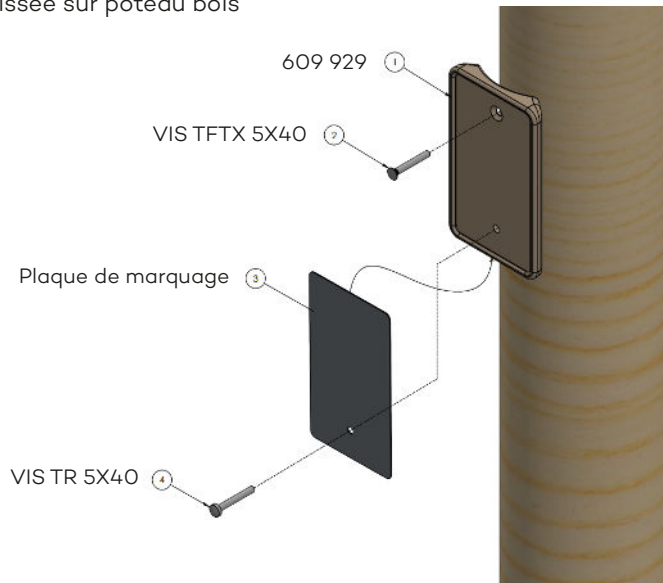

## INFORMATIONS PLAQUE DE MARQUAGE

Sollicitations corporelles

Niveau de difficulté avec curseur d'intensité

Référence de l'agrès, norme de référence, coordonnées du fabricant

COMBINE SPORTIF **BARRES FIXES** Rondino

●●● Cardio  
 ●●● Musculation  
 ●○○ Souplesse

Tractions sur les bras, la barre devant la tête, tractions sur les bras, la nuque contre la barre

---

**DIFFICULTÉ**  
●●●

Destiné aux adolescents et adultes de plus de 1.40 m

Réf. **PLAQ-CS-02**

Conforme aux exigences de sécurité de la norme NF EN 16630 : 2015  
 fabriqué par **Rondino** - Z.I. du Champ de Mars  
 230 Rue de l'Industrie, 42600 Savignieux, FRANCE

rondino.fr

QR CODE renvoyant sur vidéo d'utilisation

Illustration de l'exercice

Descriptif de l'exercice

## AUTRES EXERCICES INCLUS

<p>COMBINE SPORTIF <b>ETIREMENT DU TRONC</b> <span style="float: right; background-color: #2e8b57; color: white; padding: 2px 5px; font-weight: bold;">Rondino</span></p> <div style="display: flex; justify-content: space-between;"> <div> <p>  ●○○ Cardio   ●●● Musculation   ●●● Souplesse                 </p> </div> <div style="text-align: center;"> </div> <div style="text-align: right;"> </div> </div> <p style="text-align: center;">Flexion du tronc, bras tendus, jambes écartées</p> <hr/> <p style="text-align: center;"><b>DIFFICULTÉ</b> ●○○</p> <p style="text-align: center;">Destiné aux adolescents et adultes de plus de 1.40 m</p> <p style="text-align: center;">Réf. <b>PLAQ-CS-10</b></p> <p style="text-align: center;">Conforme aux exigences de sécurité de la norme NF EN 16630 : 2015              fabriqué par <b>Rondino</b> - Z.I. du Champ de Mars              230 Rue de l'Industrie, 42600 Savignieux, FRANCE</p> <p style="text-align: right;">rondino.fr</p>	<p>COMBINE SPORTIF <b>PLANCHE ABDOMINALE SIMPLE</b> <span style="float: right; background-color: #2e8b57; color: white; padding: 2px 5px; font-weight: bold;">Rondino</span></p> <div style="display: flex; justify-content: space-between;"> <div> <p>  ●○○ Cardio   ●●● Musculation   ●○○ Souplesse                 </p> </div> <div style="text-align: center;"> </div> <div style="text-align: right;"> </div> </div> <p style="text-align: center;">OU</p> <p style="text-align: center;">Lever les jambes à 90° puis les redescendre ou flexion avant, retour couché</p> <hr/> <p style="text-align: center;"><b>DIFFICULTÉ</b> ●●○</p> <p style="text-align: center;">Destiné aux adolescents et adultes de plus de 1.40 m</p> <p style="text-align: center;">Réf. <b>PLAQ-CS-11</b></p> <p style="text-align: center;">Conforme aux exigences de sécurité de la norme NF EN 16630 : 2015              fabriqué par <b>Rondino</b> - Z.I. du Champ de Mars              230 Rue de l'Industrie, 42600 Savignieux, FRANCE</p> <p style="text-align: right;">rondino.fr</p>	<p>COMBINE SPORTIF <b>ETIREMENT VERTEBRAL</b> <span style="float: right; background-color: #2e8b57; color: white; padding: 2px 5px; font-weight: bold;">Rondino</span></p> <div style="display: flex; justify-content: space-between;"> <div> <p>  ●○○ Cardio   ●●● Musculation   ●●● Souplesse                 </p> </div> <div style="text-align: center;"> </div> <div style="text-align: right;"> </div> </div> <p style="text-align: center;">Suspension passive</p> <hr/> <p style="text-align: center;"><b>DIFFICULTÉ</b> ●●○</p> <p style="text-align: center;">Destiné aux adolescents et adultes de plus de 1.40 m</p> <p style="text-align: center;">Réf. <b>PLAQ-CS-01</b></p> <p style="text-align: center;">Conforme aux exigences de sécurité de la norme NF EN 16630 : 2015              fabriqué par <b>Rondino</b> - Z.I. du Champ de Mars              230 Rue de l'Industrie, 42600 Savignieux, FRANCE</p> <p style="text-align: right;">rondino.fr</p>
--	--	---